



Central Coast Septics Pty. Ltd.

ABN 63 000 605 069

Registered Office;
5 Marklea Close
Tuggerah NSW 2259
PO Box 245
Wyong NSW 2259
Ph; (02) 4352 2154

Certified Product
AS/NZS 1546.1:2008
Registration Number:
464

MANUFACTURERS OF SEPTIC TANKS AND COLLECTION WELLS email: info@centralcoastseptics.com.au

SPECIFICATIONS;

- BASE;** 80mm thick reinforced with one layer of SL72 reinforcement complying AS/NZS 4671
- LID;** 80mm thick reinforced with SL72 bottom plus N12 trimmer bars sitting on top of SL72. This lid has not been designed to carry fill or other surcharge loading apart from pedestrain traffic.

CONCRETE

COVER; As per AS/NZS 1546-1;2008 minimum concrete cover is to be 20mm.

CAPACITY; Single Tank - Septic

Combined Collection Well Capacity
7100 litres

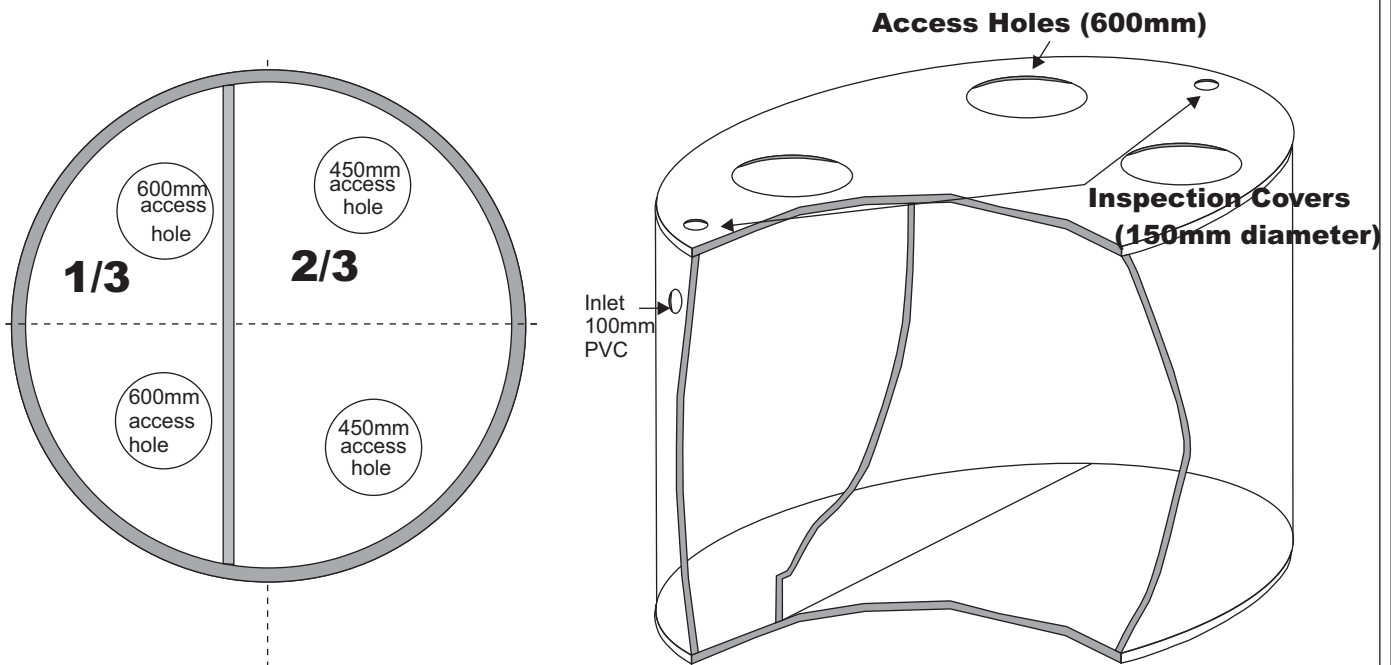

Partitions located accordingly

(A) mm	(B) mm	(C) mm	(D) mm	CAPACITY Litres
2400	1650	50	80	7100

INSTALLATION;

**NOTE THAT THE TANK IS TO BE
FOUNDED ON A BED OF UNIFORMLY COMPACTED
AND LEVELLED SAND AT LEAST 100MM THICK.**



Certified Product
AS/NZS 1546.1:2008
Registration Number:
464

Central Coast Septics Pty. Ltd.

ABN 63 000 605 069

MANUFACTURERS OF SEPTIC TANKS AND COLLECTION WELLS email:info@centralcoastseptics.com.au

Registered Office;
5 Marklea Close
Tuggerah NSW 2259
PO Box 245
Wyong NSW 2259
Ph; (02) 4352 2154

Warranty Certificate

**A WARRANTY OF 15 YEARS APPLIES TO THE TANK
AND INTERNAL TANK FITTINGS PROVIDED THE
TANK IS INSTALLED AND USED CORRECTLY**

USER FACT SHEET

- Once all your household drainage and fittings have been connected correctly to the tank, it can be used for its intended purpose.
- Avoid using strong acids, alkalis, oils, chemical in the toilet, bathroom, laundry and kitchen.
- Do use bio-degradable products, which is usually labeled on the container.
- Do spread your wash loads over six or seven days if possible to avoid hydraulic load.
- Septic tank, depending on useage, will require a desludging once every 3-5 years by a local council contractor.
- If on pump-out system, do have the collection well pumped out at least once every 7 days or in accordance with the approval from your council.
- For safety reasons, if no extra persons, ie. parties, guests, generating household waste, consider the need for pump-out of effluent more often.
- A warranty of 15 years applies to the tank and internal fittings, provided the tank is installed and used correctly.

AS/NZS 1546.1:2008 - APPENDIX 1

Installation instruction

of septic tank and/or collection well

The siting of the septic tank and/or collection well is subject to regulatory authority approval. All drainage work being carried out shall be by a licensed drainer in accordance with As3500.

- (a) A crane truck is used to deliver to the site and it is important to have sufficient access for the vehicle to reverse directly to the excavation to place the tank into the hole. Some circumstances do not allow the vehicle access to the site, e.g: wet weather, steep gradient, tress, etc. If the need arises for a crane or earthmoving equipment to lift tank to in the excavation an approved spreader bar is to be used for the safe handling of the tank.*
- (b) If tank is to be installed in ground, excavation shall allow clearance for ease of installation into the hole.
If tank is to be installed above ground, a level pad shall be prepared.*
- (c) The tank is to be founded on a bed of uniformly compacted and levelled sand at least 100mm thick.*
- (d) The lid has not been designed to carry fill or any other surcharge loading, apart from pedestrian traffic, (If lid is to be buried arrangements are to be made when purchasing and prior delivery)*
- (e) If the installation is subject to ground water, a de-watering pump may be required and concrete flange poured to the tank on manufacturing to hold the tank down and the tank needs to be filled with water to outlet.*
- (f) All fittings, inlet, outlet and partitions are installed at the factory, prior to delivery.*
- (g) The sand backfill around the tank is to be placed and tamped in horizontal layers.*
- (h) NEED TO FILL THE TANK TO OUTLET WITH WATER.*
- (I) The lid requires sealing and is done so prior delivery.*
- (j) Tank is commissioned, after final inspection by regulatory authority.*



Central Coast Septics Pty. Ltd.

ABN 63 000 605 069

Registered Office;
5 Marklea Close
Tuggerah NSW 2259
PO Box 245
Wyong NSW 2259
Ph; (02) 4352 2154

Certified Product
AS/NZS 1546.1:2008
Registration Number:
464

MANUFACTURERS OF SEPTIC TANKS AND COLLECTION WELLS email:info@centralcoastseptics.com.au

SPECIFICATIONS;

BASE; 80mm thick reinforced with one layer of SL72 reinforcement complying AS/NZS 4671

LID; 80mm thick reinforced with SL72 bottom plus N12 trimmer bars sitting on top of SL72.
This lid has not been designed to carry fill or other surcharge loading apart from pedestrain traffic.

CONCRETE

COVER; As per **AS/NZS 1546-1;2008** minimum concrete cover is to be 20mm.

Combined Collection Well Capacity
7100 litres

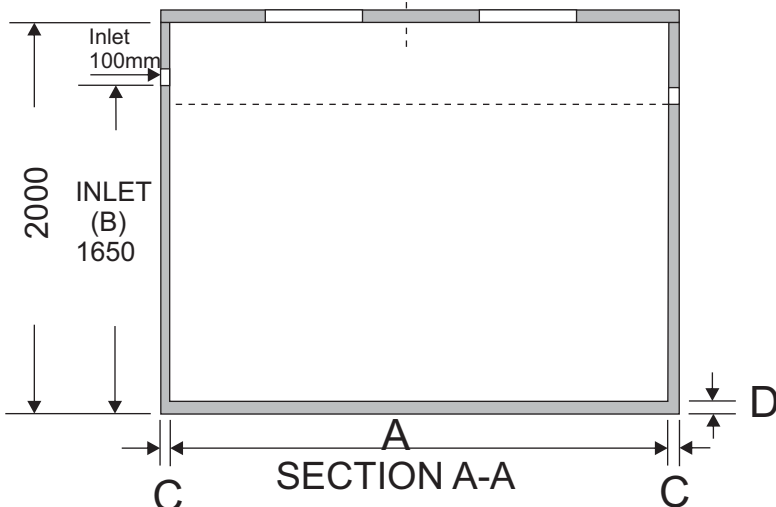
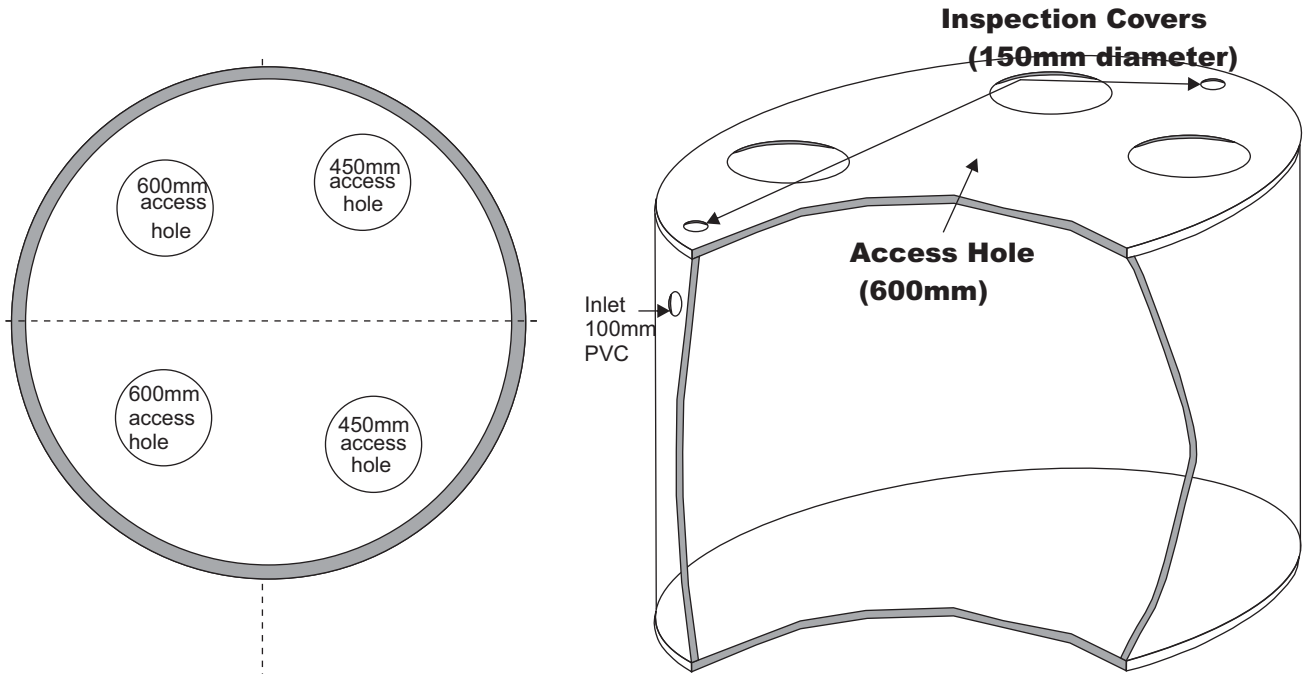

COLLECTION WELL

(A) mm	(B) mm	(C) mm	(D) mm	CAPACITY Litres
2400	1650	50	80	7100

INSTALLATION;

**NOTE THAT THE TANK IS TO BE
FOUNDED ON A BED OF UNIFORMLY COMPACTED
AND LEVELLED SAND AT LEAST 100MM THICK.**



Central Coast Septics Pty. Ltd.

ABN 63 000 605 069

Registered Office;
5 Marklea Close
Tuggerah NSW 2259
PO Box 245
Wyong NSW 2259
Ph; (02) 4352 2154

Certified Product
AS/NZS 1546.1:2008
Registration Number:
464

MANUFACTURERS OF SEPTIC TANKS AND COLLECTION WELLS email:info@centralcoastseptics.com.au

SPECIFICATIONS;

BASE; 80mm thick reinforced with one layer of SL72 reinforcement complying AS/NZS 4671

LID; 80mm thick reinforced with SL72 bottom plus N12 trimmer bars sitting on top of SL72.
This lid has not been designed to carry fill or other surcharge loading apart from pedestrain traffic.

CONCRETE

COVER; As per **AS/NZS 1546-1;2008** minimum concrete cover is to be 20mm.

Combined Collection Well Capacity
7100 litres
8500 litres

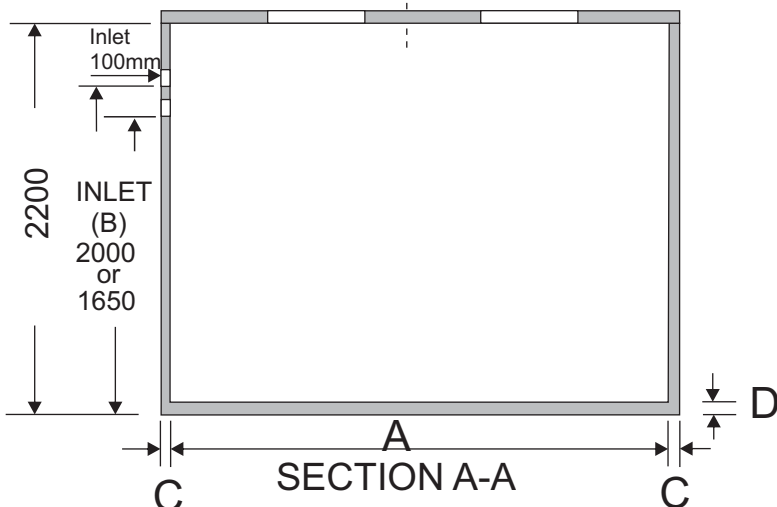
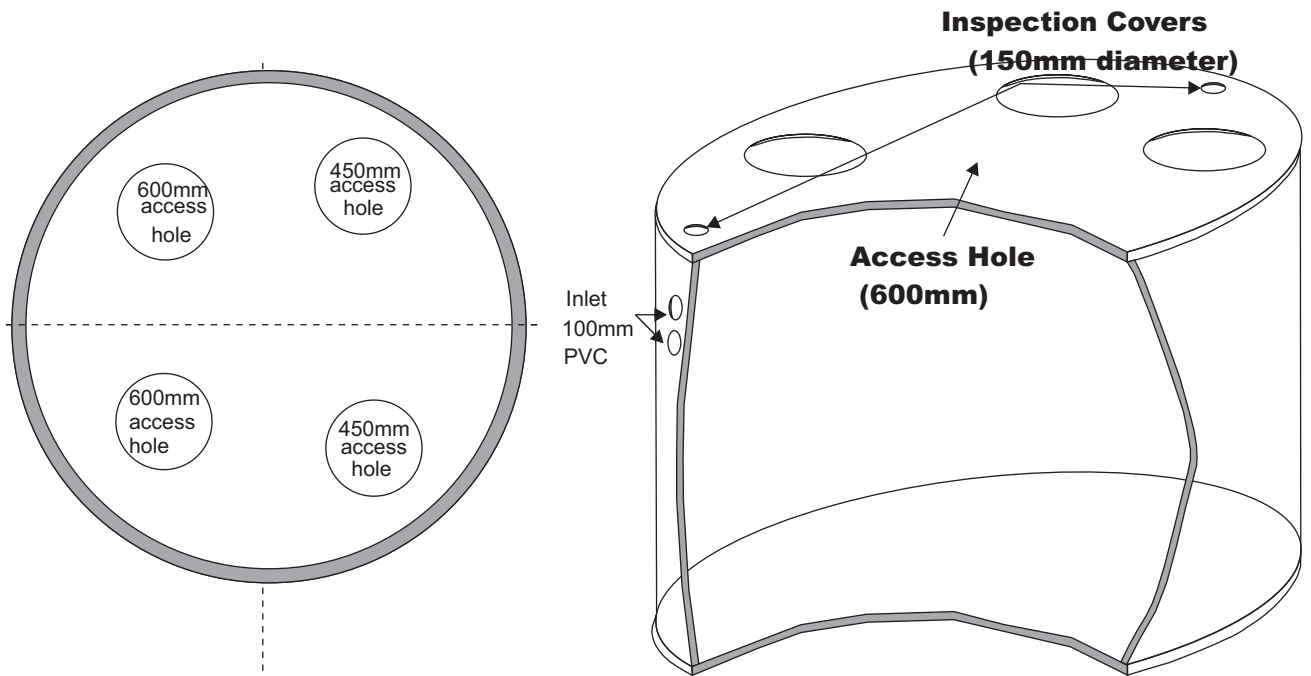

COLLECTION WELL

(A) mm	(B) mm	(C) mm	(D) mm	CAPACITY Litres
2400	2000	50	80	8500
2400	1650	50	80	7100

INSTALLATION;

**NOTE THAT THE TANK IS TO BE
FOUNDED ON A BED OF UNIFORMLY COMPACTED
AND LEVELLED SAND AT LEAST 100MM THICK.**



Central Coast Septics Pty. Ltd.

ABN 63 000 605 069

Registered Office;
5 Marklea Close
Tuggerah NSW 2259
PO Box 245
Wyong NSW 2259
Ph; (02) 4352 2154

Certified Product
AS/NZS 1546.1:2008
Registration Number:
464

MANUFACTURERS OF SEPTIC TANKS AND COLLECTION WELLS email:info@centralcoastseptics.com.au

SPECIFICATIONS;

BASE; 80mm thick reinforced with one layer of SL72 reinforcement complying AS/NZS 4671

LID; 80mm thick reinforced with SL72 bottom plus N12 trimmer bars sitting on top of SL72.
This lid has not been designed to carry fill or other surcharge loading apart from pedestrain traffic.

CONCRETE

COVER; As per AS/NZS 1546-1;2008 minimum concrete cover is to be 20mm.

CAPACITY; Single Tank Septic/Collection

1-5 person capacity;- SEPTIC (2300)- COLLECTION WELL (4600 litres)

6-10 person capacity;- SEPTIC (3050)- COLLECTION WELL (4050 litres)

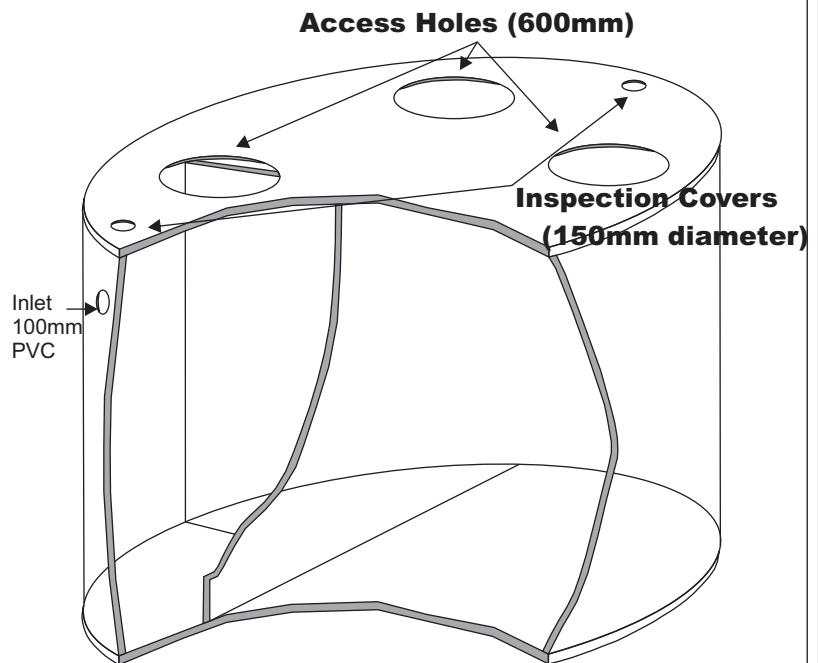
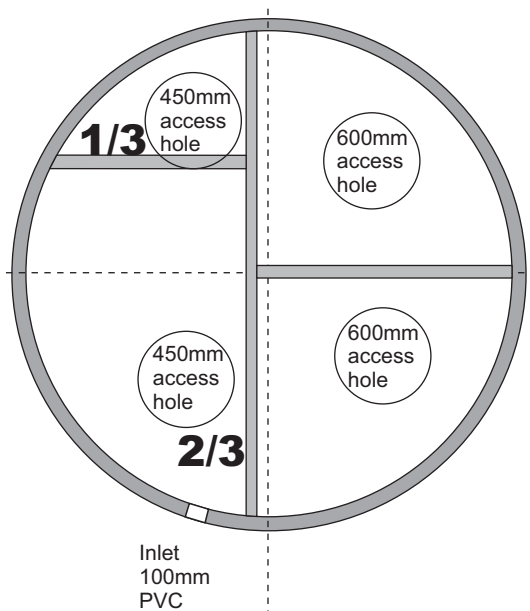

Partitions located accordingly

(A) mm	(B) mm	(C) mm	(D) mm	CAPACITY Litres
2400	1650	50	80	7100

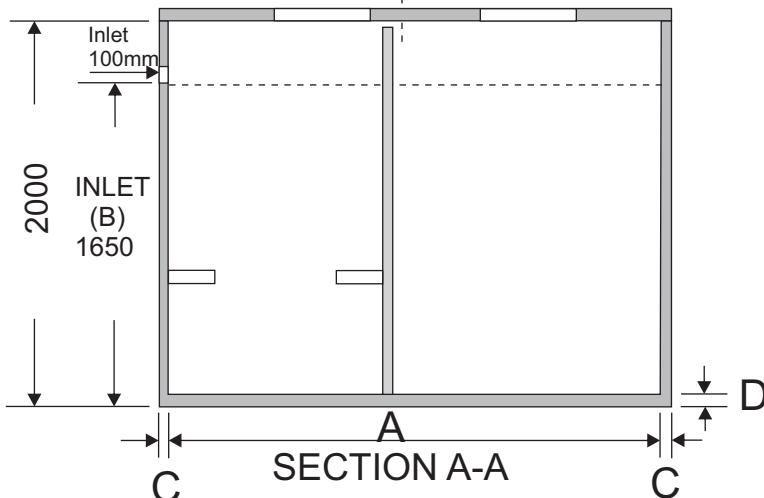

INSTALLATION;

**NOTE THAT THE TANK IS TO BE
FOUNDED ON A BED OF UNIFORMLY COMPACTED
AND LEVELLED SAND AT LEAST 100MM THICK.**



Central Coast Septics Pty. Ltd.

ABN 63 000 605 069

Registered Office;
5 Marklea Close
Tuggerah NSW 2259
PO Box 245
Wyong NSW 2259
Ph; (02) 4352 2154

Certified Product
AS/NZS 1546.1:2008
Registration Number:
464

MANUFACTURERS OF SEPTIC TANKS AND COLLECTION WELLS email:info@centralcoastseptics.com.au

SPECIFICATIONS;

BASE; 80mm thick reinforced with one layer of SL72 reinforcement complying AS/NZS 4671

LID; 120mm thick reinforced with SL72 bottom plus N12 trimmer bars sitting on top of SL72.
This lid has not been designed to carry fill or other surcharge loading apart from pedestrain traffic.

CONCRETE

COVER; As per **AS/NZS 1546-1;2008** minimum concrete cover is to be 20mm.

Combined Collection Well Capacity
10,000 litres

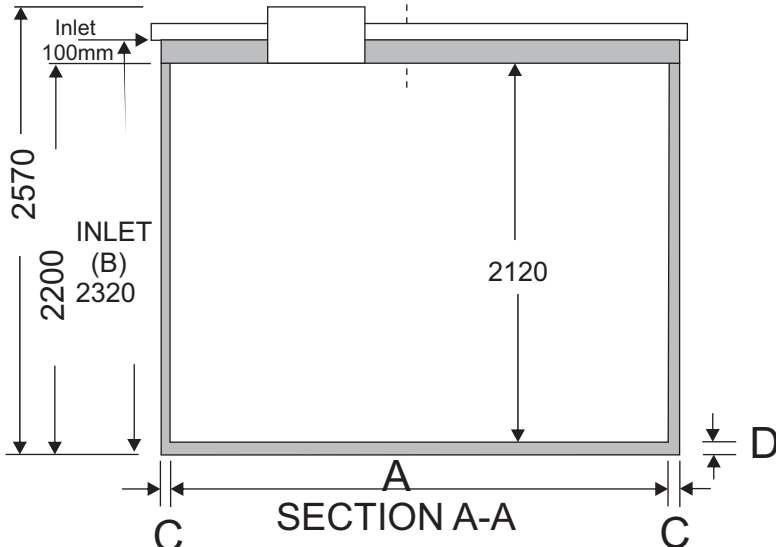
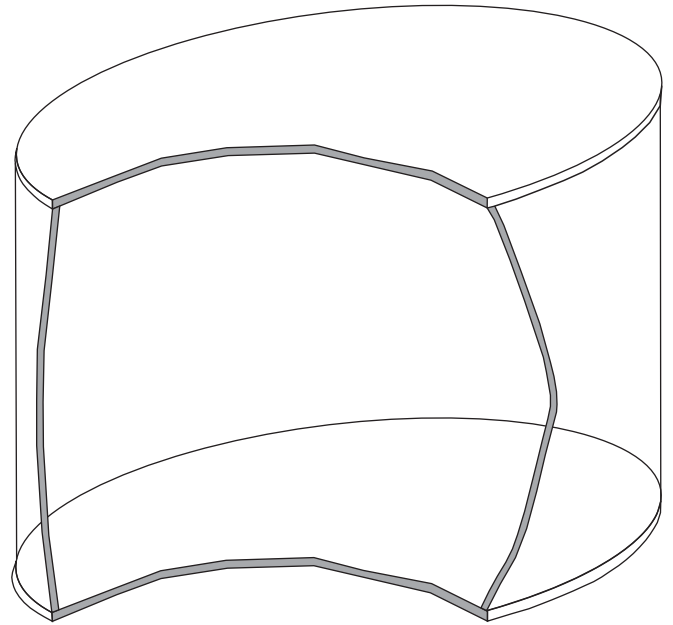
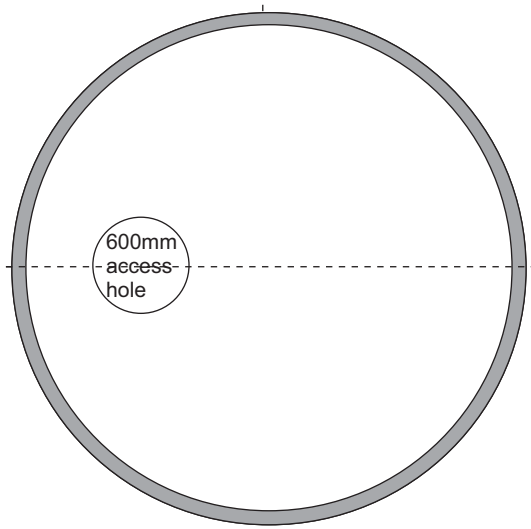

COLLECTION WELL

(A) mm	(B) mm	(C) mm	(D) mm	CAPACITY Litres
2450	2320	50	80	10,000

INSTALLATION;

**NOTE THAT THE TANK IS TO BE
FOUNDED ON A BED OF UNIFORMLY COMPACTED
AND LEVELLED SAND AT LEAST 100MM THICK.**



Central Coast Septics Pty. Ltd.

ABN 63 000 605 069

Registered Office;
5 Marklea Close
Tuggerah NSW 2259
PO Box 245
Wyong NSW 2259
Ph; (02) 4352 2154

Certified Product
AS/NZS 1546.1:2008
Registration Number:
464

MANUFACTURERS OF SEPTIC TANKS AND COLLECTION WELLS email:info@centralcoastseptics.com.au

SPECIFICATIONS;

BASE; 80mm thick reinforced with one layer of SL72 reinforcement complying AS/NZS 4671

LID; 120mm thick reinforced with SL72 bottom plus N12 trimmer bars sitting on top of SL72.
This lid has not been designed to carry fill or other surcharge loading apart from pedestrain traffic.

CONCRETE

COVER; As per **AS/NZS 1546-1;2008** minimum concrete cover is to be 20mm.

Combined Collection Well Capacity
5,200 litres

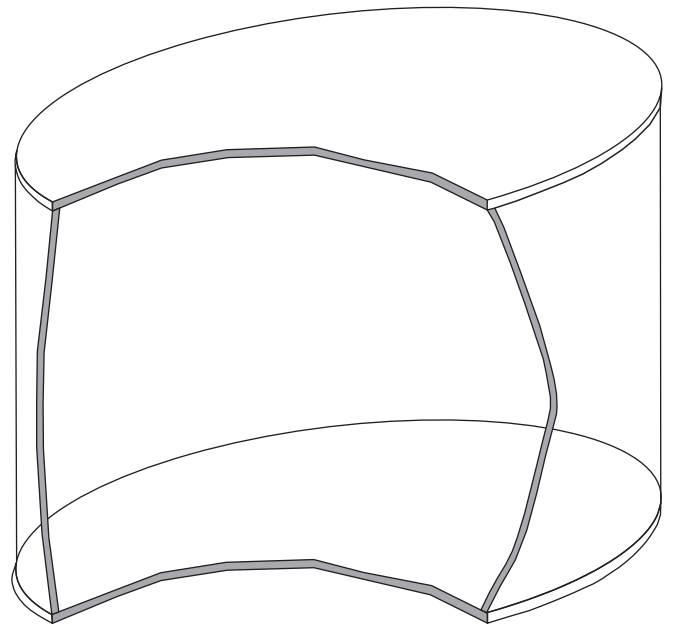
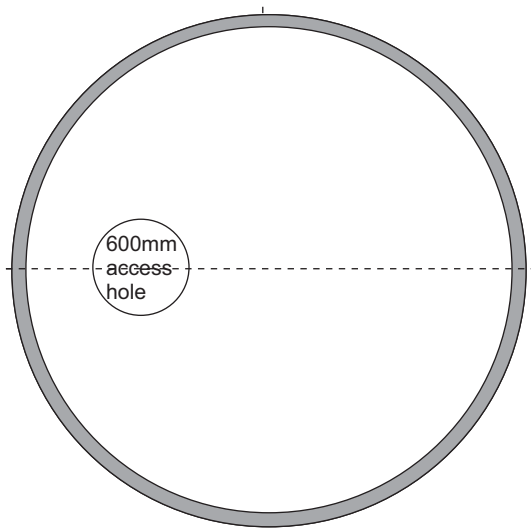

COLLECTION WELL

(A) mm	(B) mm	(C) mm	(D) mm	CAPACITY Litres
2150	1650	50	80	5,200

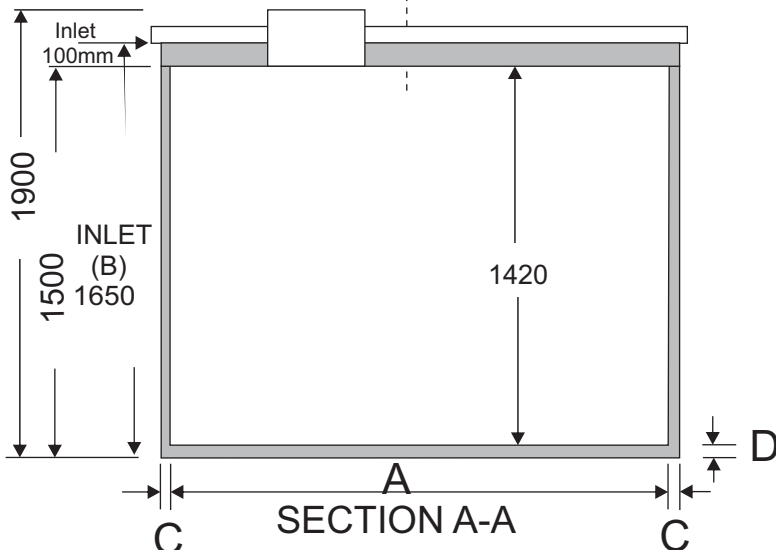

INSTALLATION;

**NOTE THAT THE TANK IS TO BE
FOUNDED ON A BED OF UNIFORMLY COMPACTED
AND LEVELLED SAND AT LEAST 100MM THICK.**



Central Coast Septics Pty. Ltd.

ABN 63 000 605 069

Registered Office;
5 Marklea Close
Tuggerah NSW 2259
PO Box 245
Wyong NSW 2259
Ph; (02) 4352 2154

Certified Product
AS/NZS 1546.1:2008
Registration Number:
464

MANUFACTURERS OF SEPTIC TANKS AND COLLECTION WELLS email:info@centralcoastseptics.com.au

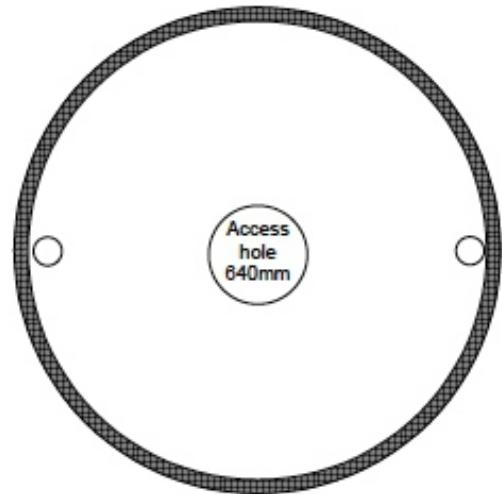
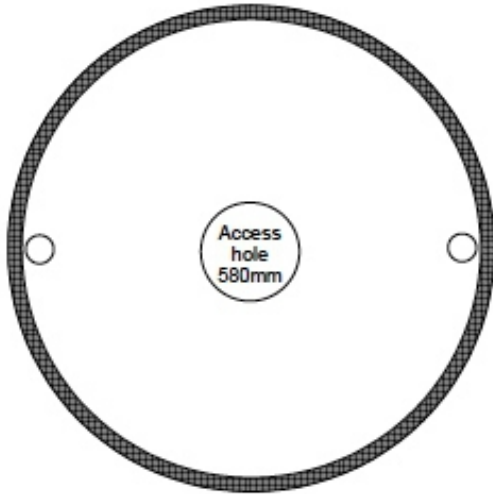
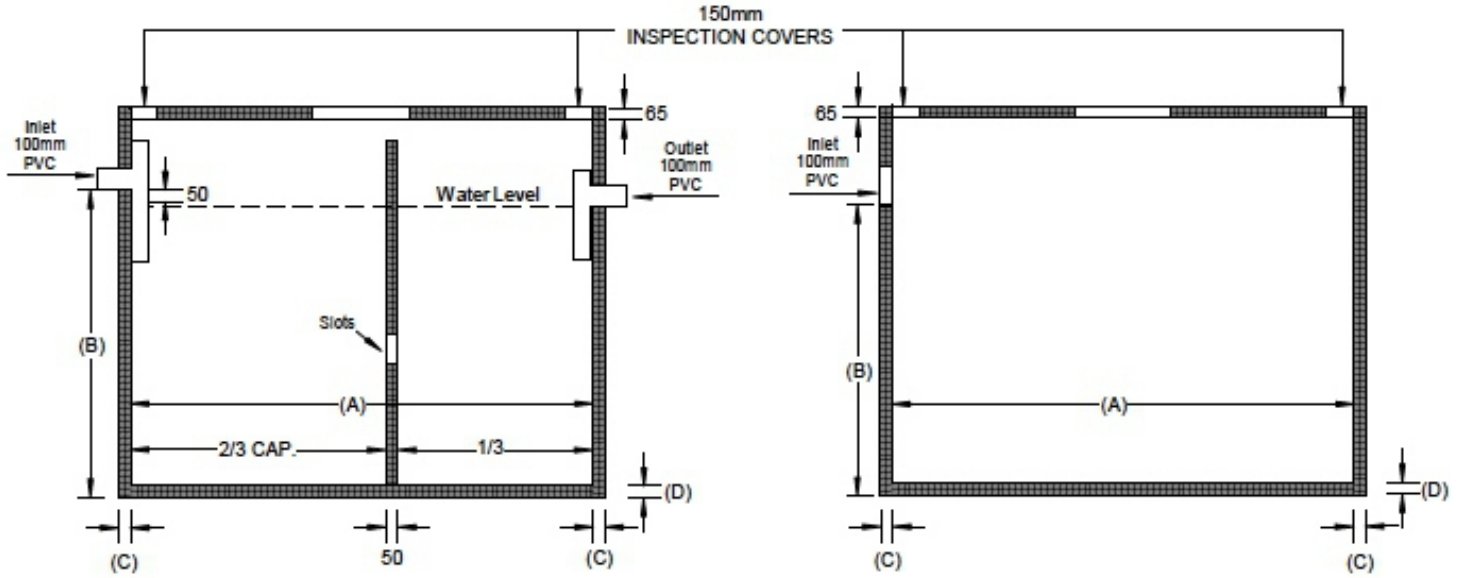

SEPTIC TANK				
A	B	C	D	LITRES
1650	1115	50	65	2050
1650	1200	50	65	2300
1830	1220	50	65	2800
1970	1440	50	65	4000

Capacity table in millimetres

OVERALL	
HEIGHT	DIAMETER
1605	1750
1605	1750
1605	1935
1818	2070

COLLECTION WELL				
A	B	C	D	LITRES
1650	1065	50	65	2050
1650	1150	50	65	2300
1830	1170	50	65	2800
1970	1390	50	65	4000

Capacity table in millimetres

SPECIFICATIONS:

*Reinforcement comply with **AS/NZS 4671**

*Partition wall only in septic tanks over 2050 litres.

*Concrete minimum compressive strength 32 MPA -- 28 days reinforced with steel mesh for base, walls and lids.

*The lid has not been designed to carry fill or any other surcharge loading apart from pedestrian.

*Tanks comply with **AS/NZS 1546-1:2008**



Central Coast Septics Pty. Ltd.

ABN 63 000 605 069

Registered Office;
5 Marklea Close
Tuggerah NSW 2259
PO Box 245
Wyong NSW 2259
Ph; (02) 4352 2154

Certified Product
AS/NZS 1546.1:2008
Registration Number:
464

MANUFACTURES OF SEPTIC TANKS AND COLLECTION WELLS email:info@centralcoastseptics.com.au

Tank Manufacture; Central Coast Septics P/L
Single Tank Collection Well / Lid
AS/NZS 1546.1

SPECIFICATIONS

BASE: 65mm thick reinforced with steel fibre
as per AS/NZ 1546.1:2008

LID: 120mm thick reinforced with steel fibre
as per AS/NZ 1546.1:2008
This lid has been designed to carry fill or
pedestrian traffic.

CONCRETE COVER; As per AS/NZS 1546.1 minimum
concrete cover is to be 20mm

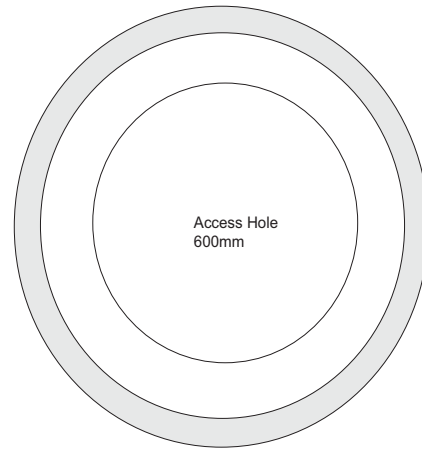

INSTALLATION

NOTE that the tank is to be
found on a bed of uniformly
compacted and levelled sand
at least 100mm thick

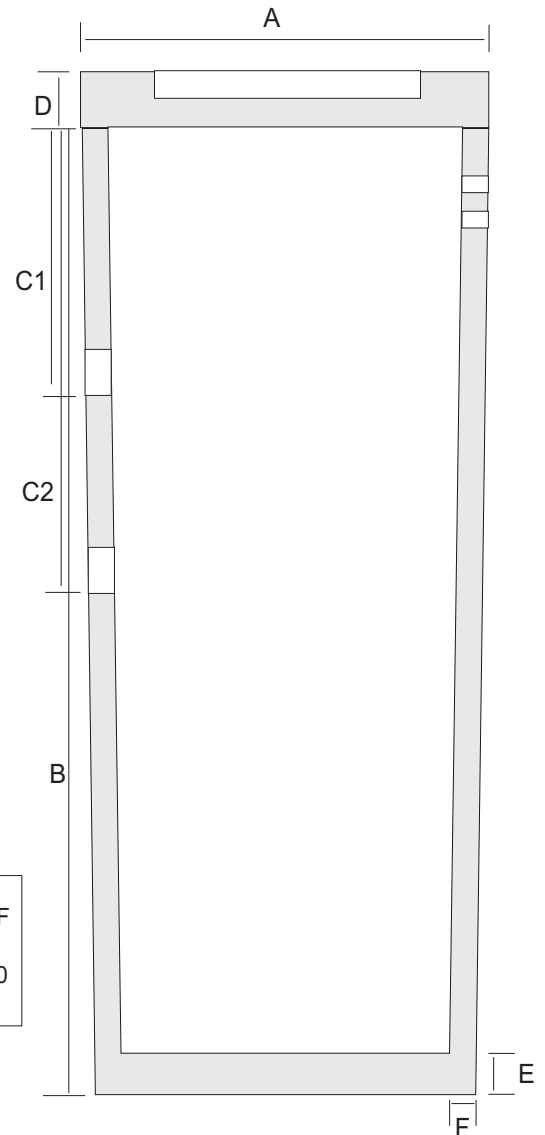

CAPACITY	A	B	C1	C2	D	E	F
Es900	935mm	2065mm	575	995	120	65	60